



TIGHTNESS CLASS



MATERIAL



BACTERIOSTATIC

# Plenum Box

VPB125-3

The AWENTA PRO VPB125-3 plenum box is used to connect three flexible air ducts to the distribution boxes. Thanks to the possibility of supplying up to three ducts, it is recommended for mounting air valves in rooms requiring intensive ventilation, e.g. kitchen, bathroom or toilet. The high air flow efficiency of the VPB125-3 box makes it possible to achieve increased ventilation parameters without having to drill additional holes in the ceiling.

The AWENTA PRO plenum boxes are made of durable HDPE (High Density Polypropylene) with a bacteriostatic Nano-Silver additive. The robust structure guarantees failure-free operation for many years and thanks to the use of a bacteriostatic additive the product has obtained a very high level of bacteriostatic activity.

The design of the plenum box allows it to be mounted on different surfaces and in different planes. The Ø75 mm female connectors are equipped with a gasket and special protection of the connected ducts, which ensures the tightness of the entire system in the high ATC1 class. Mounting of the box is facilitated by brackets allowing for the installation height adjustment that adapts to the place of installation. They guarantee the quick and easy installation of the plenum boxes in the system.

It is possible to install them on floor / wall / ceiling:  
made of concrete or plasterboard.



## AIR FLOW CHARACTERISTICS

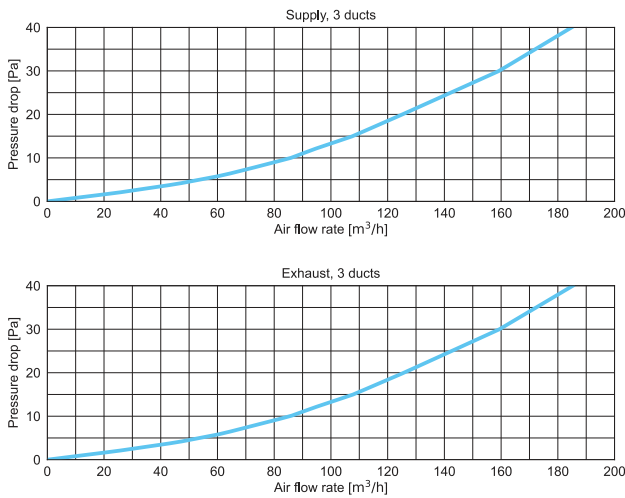

## DIMENSIONS

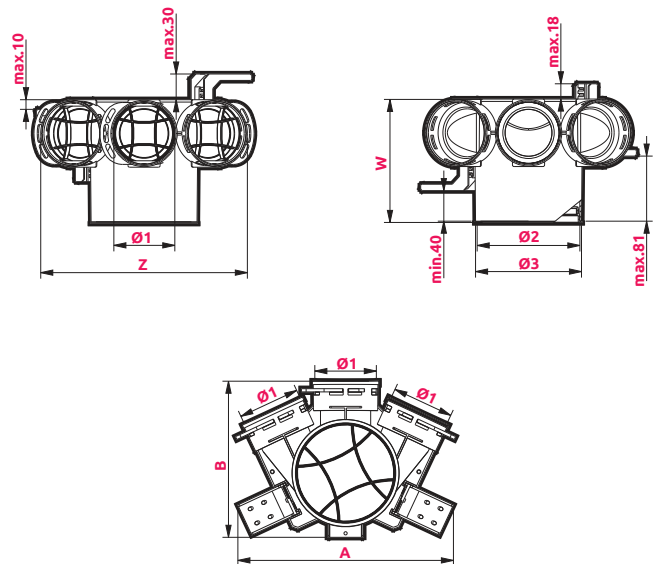

	Ø1	Ø2	Ø3	A	B	Z	W
VPB125-3	75	128	134	268	195	257	152

WITH **NANOSILVER** ADDITIVE  
ELIMINATING UP TO 99% BACTERIA

